

NITCHI

No. 8

NITCHI-MATIC ELECTRIC CHAIN HOIST MH-5 SERIES



NITCHI-MATIC HEAVY DUTY

The NITCHI-MATIC Model MH-5 Series is a line of premium quality electric chain hoists that are designed especially to fulfill the severe requirements of industry. A multitude of special heavy duty features are employed into the NITCHI-MATIC MH-5 Series for extra efficiency, dependability, durability and safety.

STEEL CONSTRUCTION

The main frame consists of two rugged steel side plates that will provide maximum protection against dynamic loads. Castings that are able to crack or break have not been employed in the main frame.

WEAR-RESISTANT LOAD SHEAVE & CHAIN GUIDE

The load sheave is made of alloy steel that is expertly machined and heat-treated for long wearing, smooth engagement with the load chain. The load chain guide directs the load chain smoothly into the NITCHI-MATIC for positive engagement with the load sheave.

HEAVY DUTY MOTOR

The special heavy duty high performance motors of Model MH-5 (1-Speed) have 30 minutes ratings and Class B insulation for severe use in heavy duty applications.

ELECTROMAGNETIC BRAKE

This powerful brake system responds instantly and supplies dependable positive braking power. An extremely long service life has been achieved with the use of non-asbestos brake linings.

OVER-HOISTING & OVER-LOWERING PROTECTION

Possibilities of damage to the NITCHI-MATIC caused by over-hoisting and over-lowering are eliminated with the limit switch.

Ultra-Tough Load Chains

The NITCHI casehardened load chains are made from special alloy steel, and are given super-tough carbonized hard surfaces that resist erosion several times longer than conventional through hardened load chains. The soft core section gives the load chain the elasticity which is essential for material lifting equipment. Every link of load chain is tested, and a record of each chain production lot is kept on record at our factory.

FORGED STEEL HOOKS

Both the top and bottom hooks on all capacities swivel to all directions and are made of drop-forged steel that is heat-treated for greater strength. Every bottom hook is equipped with a thrust bearing for smooth rotation and has a safety latch as a standard equipment.



INDUSTRIAL HOIST

MH-5 SERIES

OIL BATH LUBRICATION

As in all types high quality machinery the NITCHI-MATIC Series uses the oil bath lubrication system. The continuous bath of oil lubricates the reduction gear system and also acts as a coolant for the mechanical brake.

ANTIPHASE PROTECTION RELAYS

This relay prevents damage to the hoist cause by misconnections (negative phase connections) of the power source wires.

FIRST STAGE HELICAL GEARING

The first stage helical gearing provides a dependable and longer quieter life by reducing gear tooth impact and vibration to a minimum. The reduction gears are exclusively designed for extra durability and are made of special alloy steel that is expertly machined for positive engagement and precisely heat-treated for maximum strength.

MECHANICAL BRAKE

The very reliable mechanical brake works in cooperation with the electromagnetic brake and holds suspended loads at any point.

PUSH-BUTTON SWITCH

The strong light-weight push-button switch of NITCHI-MATIC is rainproof and responds immediately at a touch of the button.

WIDE SELECTION

NITCHI-MATIC is a series of electric chain hoists with standard capacities ranging from 0.5 ton to 50 ton that are available in a wide variety of variations for handling nearly all material handling requirements. The industrial type 3-phase power source version can be used independently as a suspended type electric chain hoist or as an electric chain hoist directly coupled to a manual operated trolley or a motorized trolley. The lifting speed of the NITCHI-MATIC can be selected between single-speed and 2-speed whichever most adequately fulfills your requirements for increasing productivity. Also, a single phase power source version is available for light materials handling operations and home use where 3-phase power sources are not readily available.

INCREASED DURABILITY

Durability is one of the main features we are able to boast about. The NITCHI-MATIC MH-5 Series is designed and made to the Grade M4 and M5 durability standards of the Japanese Industrial Standard.

HIGH DUTY RATING

A high duty rating is essential for fulfilling the severe work cycles that are required for production in industry. The 40% ED rating of Model MH-5 (1-Speed) is sufficient for almost all heavy duty industrial applications.

DUAL BRAKING SYSTEM

Two completely independent brakes not only reduce the possibility of brake failure, but also increase the braking surface and contribute to the dissipation of heat generated by repeated braking.

SHORT HEADROOM

The ingeniously designed compact construction of NITCHI-MATIC makes it extremely compact and permits the highest possible lift where the last inch of lift must be obtained.

24-VOLT CONTROL

The low 24-volt control protects the operator from harmful electrical shocks.

EASY SERVICING

The robust pressed steel design simplifies the maintenance and the replacement of components.

USEFUL MANUAL

Each NITCHI-MATIC hoist is supplied with a comprehensive handbook that provides sufficient instructions and information on installation, operation and maintenance.

OPTIONAL EQUIPMENT

OVERLOAD PROTECTION

This is a special device for additional safety to operators, hoist and load. When a load that is greater than the setting of the overload protection is applied, the hoist will stop automatically and prevent the load from being hoisted.

NN CASEHARDENED CHAIN

This is a series of Nitchi casehardened chains with a special non-electrolytic nickel plating that is fused into the material of the chains. This special plating does not effect the original features of the chains and will not peel off like conventional surface plated chains. The NN casehardened chains have outstanding characteristics in resisting rust and corrosion caused by rain, seawater, steam and chemicals.



Casehardened
NN Chain

Standard
Casehardened Chain

NITCHI-MATIC ELECTRIC CHAIN HOIST

MODEL MH-5

The single load chain fall design of 3 ton and the exceptionally low headrooms of Model MH-5 are the results of the streamlined, robust steel constructions and well balanced designs.

Model MH-5 1-speed hoist is available in a wide range of standard capacities for your choice..... available from light 0.5 ton loads to extremely heavy 50 ton loads. Please refer to succeeding page for specifications of 10 ton and larger capacities.



MH-5 SINGLE Voltage - 3P 380V

MH-5D DUAL Voltage - 3P 220/380V

MH-5D is the standard model for Thailand

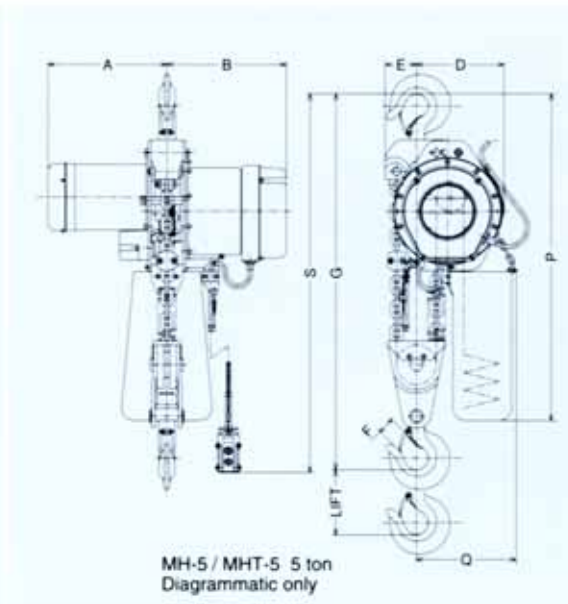
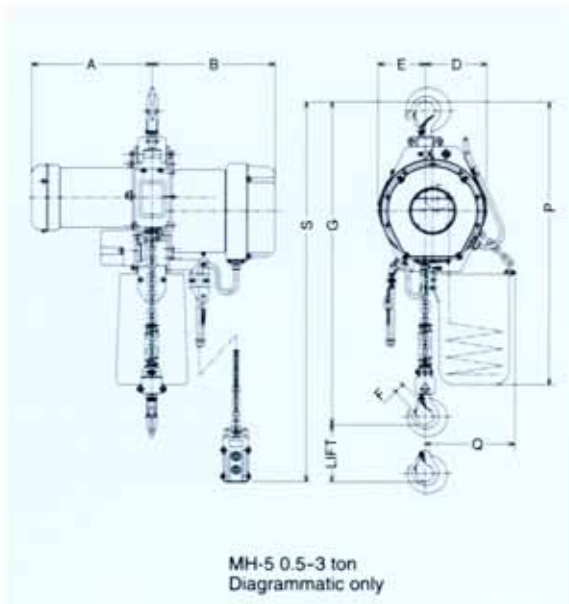

STANDARD SPECIFICATIONS : MH-5 Electric Chain Hoist

Item No.	Rated load (ton)	Lift (m)	Hoisting Speed(m/min)		Hoist Motor 3-phase					Load Chain		Test Load (ton)	Minimum Headroom (Max.) G (mm)	Net Weight ⊕ (approx.) (≈ kg)	Grade
			50Hz	60Hz	Output(kw)		Ins. Class	Rating (min)	% ED	Dia. (mm)	Nos. of falls				
					50Hz	60Hz									
MH5005	0.5	4.0	8.6	10.0	0.83	1.0	B	30	40	7.1	1	0.625	550	53	M5
MH5010	1		6.2	7.3	1.17	1.4				7.1	1	1.25	560	55	M5
MH5020	2		6.7	7.9	2.5	3.0				11.2	1	2.5	725	100	M5
MH5030	3		4.4	5.2	2.5	3.0				11.2	1	3.75	765	102	M4
MH5050	5		2.6	3.1	2.5	3.0				11.2	2	6.25	925	130	M4

Item No.	Rated load (ton)	Major Dimensions (approx.) (mm)								
		A	B	D	E	F	⊕P	⊕Q	S(m)	
MH5005	0.5	265	285	152	106	20	690	220	3.6	
MH5010	1	285	285	152	106	25	690	220	3.6	
MH5020	2	335	335	195	127	30	860	235	3.8	
MH5030	3	335	335	195	127	36	880	235	3.8	
MH5050	5	335	335	247	93	43	960	290	3.8	

NOTES:

- a - Only the standard lifts hoists, are enumerated above. Please apply for extra long lifts.
- b - Please state power source voltage and Herz on enquiry and or ordering.
- c - 4-core colored cords with rubber-covered power source cable is supplied, without plug
- d - A chain collecting bucket is supplied with each hoist as standard attachment.

NITCHI-MATIC ELECTRIC CHAIN HOIST WITH ELECTRIC TROLLEY

MODEL EMT-MH-5

In addition to hoisting and lowering, Model EMT-MH-5 (1-speed hoist with 1-speed trolley) can transport heavy loads swiftly with great efficiency and complete safety. 1/2 ton to 7.5 ton trolleys can be adjusted to fit the different beam sizes listed in the table by simple relocation of the spacing washers to the inside or to the outside of the frame.

The drop-forged steel trolley wheels are heat-treated and have precision bearings to provide smooth and easy travel.

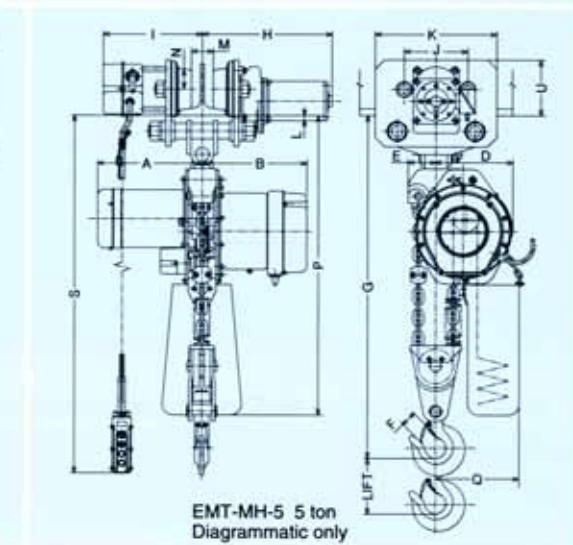
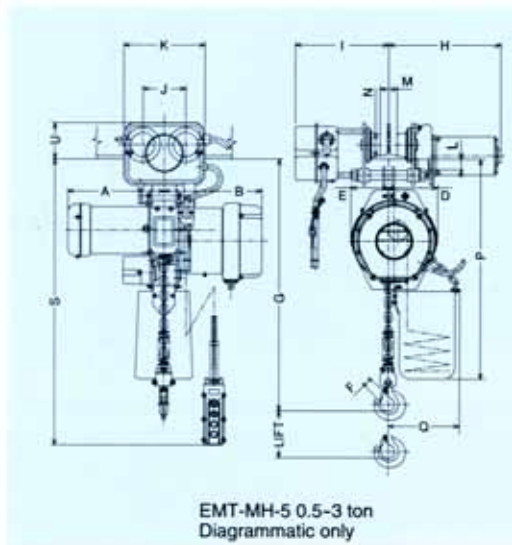
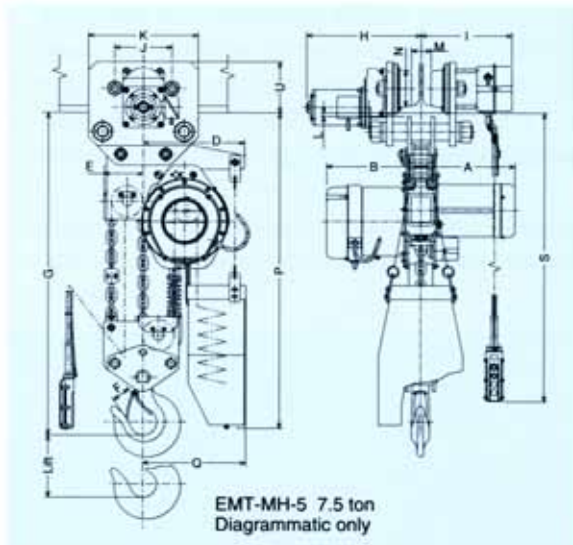

STANDARD SPECIFICATIONS : EMT-MH-5 Electric Chain Hoist with Electric Trolley

Item No.	Rated load (ton)	Lift (m)	Hoist Motor						Traversing Speed(m/min)		Trolley Motor				Test Load (ton)	Minimum Headroom (Max.) G (mm)	Net Weight \approx (approx.) (\pm kg)			
			Hoisting Speed (m/min)		3-phase		Load Chain		50Hz	60Hz	3-phase		Breadth of Beams b (mm)	Minimum radius for curve (m)						
			50Hz	60Hz	Output(kw)	Ins. Class	Rating (min)	Dia. (mm)			Nos. of falls	Output (kw)						Ins. Class	Rating (min)	
MHE5005	0.5	4.0	8.6	10.0	0.83	1.1	B	30	7.1	1	20(10)	24(12)	0.2	E	30	75, 100, 125	1.0	0.625	535	84
MHE5010	1		6.2	7.3	1.17	1.4			7.1	1	20(10)	24(12)	0.2			75, 100, 125	1.0	1.25	545	86
MHE5020	2		6.7	7.9	2.5	3.0			11.2	1	20(10)	24(12)	0.4			100, 125, 150	1.0	2.5	725	153
MHE5030	3		4.4	5.2	2.5	3.0			11.2	1	20(10)	24(12)	0.4			100, 125, 150	1.5	3.75	805	172
MHE5050	5		2.6	3.1	2.5	3.0			11.2	2	20(10)	24(12)	0.75(0.4)			125, 150, 175	1.5	6.25	975	219
MHE5075	7.5		1.7	2.1	2.5	3.0			11.2	3	10(5)	12(6)	0.75			150, 175	1.5	9.37	1,065	290

Item No.	Rated load (ton)	Major Dimension (approx.) (mm)															
		A	B	D	E	F	H	I	J	K	L	M	N	U	\approx P	\approx Q	S (m)
MHE5005	0.5	265	285	152	106	20	b/2+280	b/2+230	127	240	32-t ₁	b-49	ϕ 69	99+t ₁	675	220	4.0
MHE5010	1	285	285	152	106	25	b/2+280	b/2+230	127	240	32-t ₁	b-49	ϕ 69	99+t ₁	675	220	4.0
MHE5020	2	335	335	195	127	30	b/2+325	b/2+235	159	300	33-t ₁	b-70	ϕ 95	121+t ₁	860	235	4.0
MHE5030	3	335	335	195	127	36	b/2+330	b/2+240	180	340	37-t ₁	b-76	ϕ 110	134+t ₁	920	235	4.0
MHE5050	5	335	335	247	93	43	b/2+330	b/2+245	204	390	38-t ₁	b-80	ϕ 130	158+t ₁	1,010	290	4.0
MHE5075	7.5	335	335	360	145	65	b/2+340	b/2+335	204	390	38-t ₁	b-80	ϕ 130	158+t ₁	1,140	400	4.3

e - The values in the () are for electric trolleys with half speed.
 f - The dimensions P and Q marked * in the above table vary according to different lifts.
 g - With each hoist is packed a handbook giving comprehensive instructions for installation, and operation with an inspection certificate.

The design, materials and specifications are subject to change for improvements without notice.

NITCHI-MATIC ELECTRIC CHAIN HOIST WITH GEARED/PLAIN TROLLEYS

MODEL MHG-5/MHP-5

The NITCHI geared and plain trolleys in this pamphlet are designed exclusively for the NITCHI-MATIC and are ideal for efficient and safe transportation of loads. 0.5 ton to 7.5 ton capacities geared and plain trolleys can be adjusted to fit the different beam sizes listed in the table simply by relocating the spacing washers to the inside or to the outside of the frame.

The ingenious direct-coupling connection makes the headroom remarkably short and always faces the hoist in the same direction.

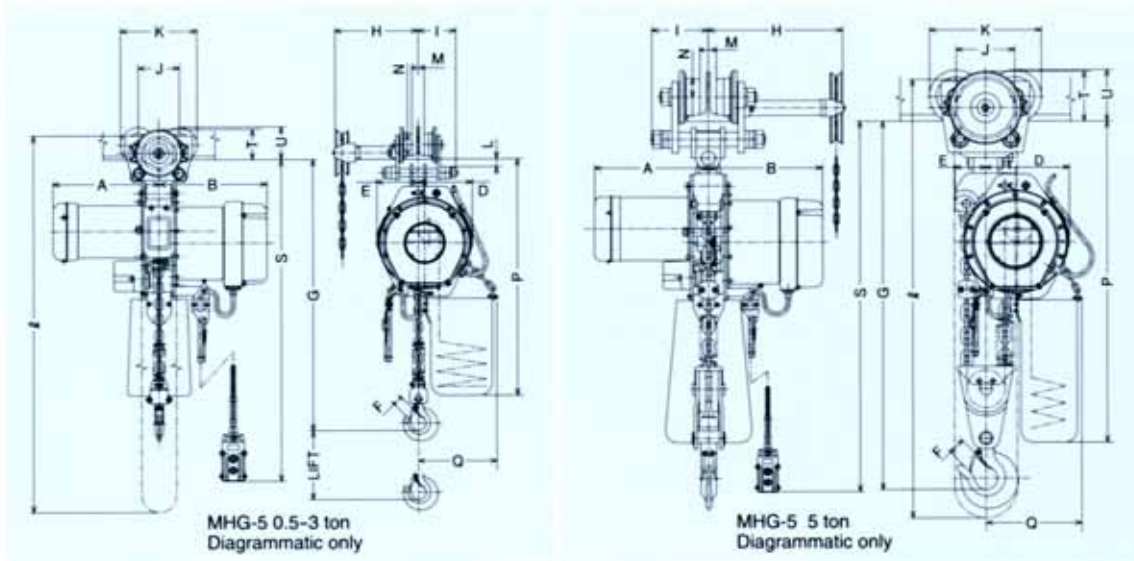

STANDARD SPECIFICATIONS : MHG-5 Electric Chain Hoist with Geared Trolley & MHP-5 Electric Chain Hoist with Plain Trolley

Item No.	Rated load (ton)	Lift (m)	Hoisting Speed(m/min)		Hoist Motor 3-phase		Load Chain		Test Load (ton)	Breadth of Beams b (mm)	Minimum radius for curve (m)	Minimum Headroom (Max.) G (mm)	
			50Hz	60Hz	Output (kw)		Rating (min)	Dia. (mm)					Nos. of falls
					50Hz	60Hz							
MHG5005 MHP5005	0.5	4.0	8.6	10.0	0.83	1.0	30	7.1	1	0.625	75, 100, 125	1.0	515
MHG5010 MHP5010	1		6.2	7.3	1.17	1.4		7.1	1	1.25	75, 100, 125	1.0	525
MHG5020 MHP5020	2		6.7	7.9	2.5	3.0		11.2	1	2.5	100, 125, 150	1.2	710
MHG5030 MHP5030	3		4.4	5.2	2.5	3.0		11.2	1	3.75	100, 125, 150	1.5	770
MHG5050 MHP5050	5		2.6	3.1	2.5	3.0		11.2	2	6.25	125, 150, 175	1.5	955
MHG5075 MHP5075	7.5		1.7	2.1	2.5	3.0		11.2	3	9.375	150, 175	3.0	1080

Item No.	Rated load (ton)	Major Dimensions (MHG-5 · MHP-5)														MHG-5			MHP-5			
		A	B	D	E	F	J	K	L	M	N	U	⊕P	⊕Q	S (m)	ℓ (m)	H (mm)	I (mm)	T (mm)	Net Weight ⊕ (±kg)	H, I (mm)	Net Weight ⊕ (±kg)
MHG5005 MHP5005	0.5	265	285	152	106	20	110	206	24-t	b-42	∅62	80+t	655	220	3.6	4.0	b/2+189	105	72+t	71	105	61
MHG5010 MHP5010	1	285	285	152	106	25	110	206	24-t	b-42	∅62	80+t	655	220	3.6	4.0	b/2+189	105	72+t	73	105	63
MHG5020 MHP5020	2	335	335	195	127	30	140	262	28-t	b-63	∅83	102+t	845	235	3.8	4.0	b/2+150	127	115+t	126	127	116
MHG5030 MHP5030	3	335	335	195	127	36	160	306	27-t	b-63	∅107	126+t	885	235	3.8	4.0	b/2+150	133	118+t	139	133	130
MHG5050 MHP5050	5	335	335	247	93	43	172	329	35-t	b-76	∅110	134+t	990	290	3.8	4.0	b/2+339	166	130+t	185	166	175
MHG5075 MHP5075	7.5	335	335	360	145	65	222	420	42-t	b-84	∅155	175+t	1160	400	4.0	4.6	b/2+326	186	161+t	280	—	—

N.B. The dimensions P and Q marked *above vary according to different lifts.

The design, materials and specifications are subject to change for improvements without notice.

NITCHI-MATIC TWO-SPEED ELECTRIC CHAIN HOIST

MODEL MHT-5

MHT-5 2-speed electric chain hoist has a 4 to 1, fast to slow lifting speed ratio. Depressing the push button switch is all that is needed to efficiently handle material with the slow-speed or fast-speed. The slow-speed is particularly effective for accurately spotting a load without having to do the harmful inching operation. Like the MH-5 single-speed electric chain hoists, the MHT-5 2-speed electric chain hoists are also available directly coupled to manual trolleys or to motorized trolleys. 2-speed motorized trolleys with 3 to 1, fast to slow traversing speed ratio are also available. You can obtain maximal working efficiency with the ultimate combination of a 2-speed electric chain hoist with 2-speed motorized trolley.

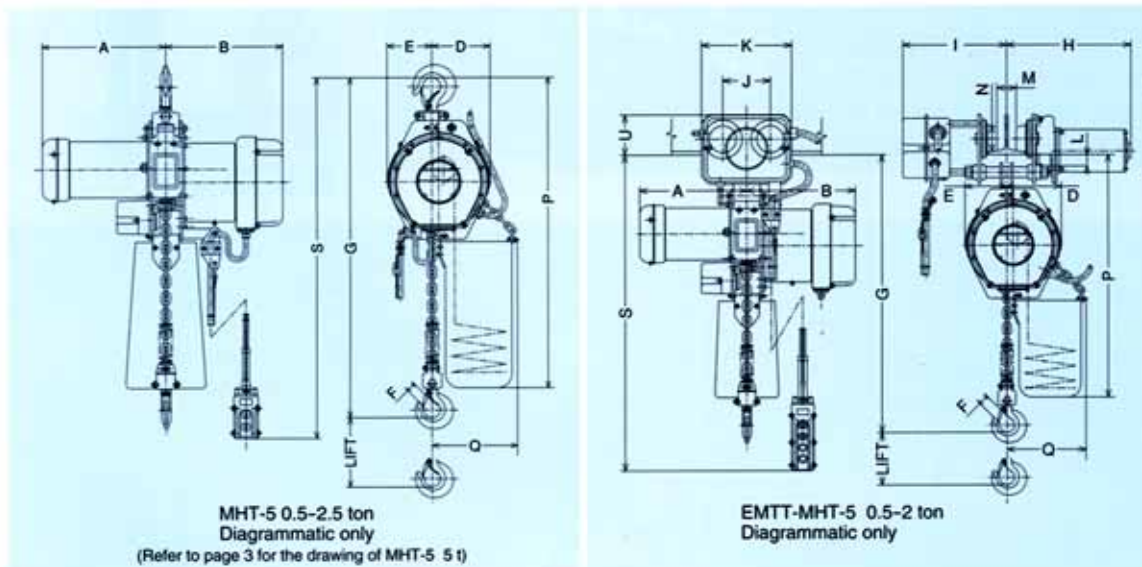

STANDARD SPECIFICATIONS : MHT-5 Two-Speed Electric Chain Hoist (Single-voltage)

Item No.	Rated Load (ton)	Lift (m)	Hoisting Speed(m/min)				Hoist Motor 3-phase					Load Chain		Test Load (ton)	Minimum Headroom (Max.) G (mm)	Net Weight ± (approx.) (±kg)	Grade			
			Fast		Slow		Output (kW)			Ins. Class	Rating (min)		% ED					Dia. (mm)	Nos. of falls	
			50Hz	60Hz	50Hz	60Hz	Fast	Slow	60Hz		Fast	Slow								
MT5005	0.5	4.0	8.0	9.4	1.9	2.2	0.83	1.0	0.21	0.25	B	20	20	25	7.1	1	0.625	550	55	M5
MT5010	1		4.3	5.0	1.0	1.2	0.83	1.0	0.21	0.25					7.1	1	1.25	560	56	M4
MT5020	2		4.8	5.6	1.2	1.4	1.83	2.2	0.46	0.55					11.2	1	2.5	725	103	M5
MT5025	2.5		3.8	4.4	1.0	1.1	1.83	2.2	0.46	0.55					11.2	1	3.125	765	105	M4
MT5050	5		1.9	2.2	0.5	0.6	1.83	2.2	0.46	0.55					11.2	2	6.25	925	133	M4

Item No.	Rated Load (ton)	Major Dimension (approx.) (mm)								
		A	B	D	E	F	±P	±Q	S (m)	
MT5005	0.5	305	285	152	106	20	795	220	3.6	
MT5010	1	305	285	152	106	25	795	220	3.6	
MT5020	2	365	335	195	127	30	860	235	3.8	
MT5025	2.5	365	335	195	127	36	880	235	3.8	
MT5050	5	365	335	247	93	43	960	290	3.8	

STANDARD SPECIFICATIONS : EMTT-MHT-5 Two-Speed Electric Chain Hoist with Two-Speed Electric Trolley (Single-voltage)

Item No.	Rated Load (ton)	Lift (m)	Traversing Speed(m/min)				Output (kW)		Ins. Class	Rating (min)	Breadth of Beams b (mm)	Minimum radius for curve (m)	Test Load (ton)	Minimum Headroom (Max.) G (mm)	Net Weight ± (approx.) (±kg)	Major Dimension (approx.) (mm)																
			Fast		Slow		Fast	Slow								A	B	D	E	F	H	I	K	L	M	±P	±Q	U				
			50Hz	60Hz	50Hz	60Hz	Fast	Slow	Fast	Slow	Fast	Slow	Fast	Slow	Fast	Slow	Fast	Slow	Fast	Slow	Fast	Slow										
MTET5005	0.5	4.0	20	24	6.5	8	0.2	0.07	E	Fast 30 Slow 15	75,100,125	1.0	0.625	535	96	305	285	152	106	20	b/2 +330	b/2 +240	240	32±t	b-49	780	220	99±t				
MTET5010	1		1.25	545	98	25	25	25					25	25	25	25	25	25	25	25	25	25	25	25	25	25	25	25	25	25	25	25
MTET5020	2		2.5	725	168	365	335	195					127	30	b/2 +360	b/2 +240	300	33±t	b-70	860	235	121±t										

NOTES:
For NITCHI-MATIC TWO-SPEED Hoist with directly coupled trolleys, please apply for information.
N.B. The dimensions P and Q marked *above vary according to different lifts.

The design, materials and specifications are subject to change for improvements without notice.

NITCHI-MATIC ELECTRIC CHAIN HOIST WITH SINGLE-PHASE MOTORS

MODEL MHC-5

The specially developed high performance capacitor-start induction motors of Model MHC-5 single-phase hoist are extremely long wearing and will enable reliable handling of heavy loads on household power sources.

When used together with a Nitchi trolley, it will be possible to use Model MHC-5 on a large variety of applications for the efficient and safe transportation of loads.

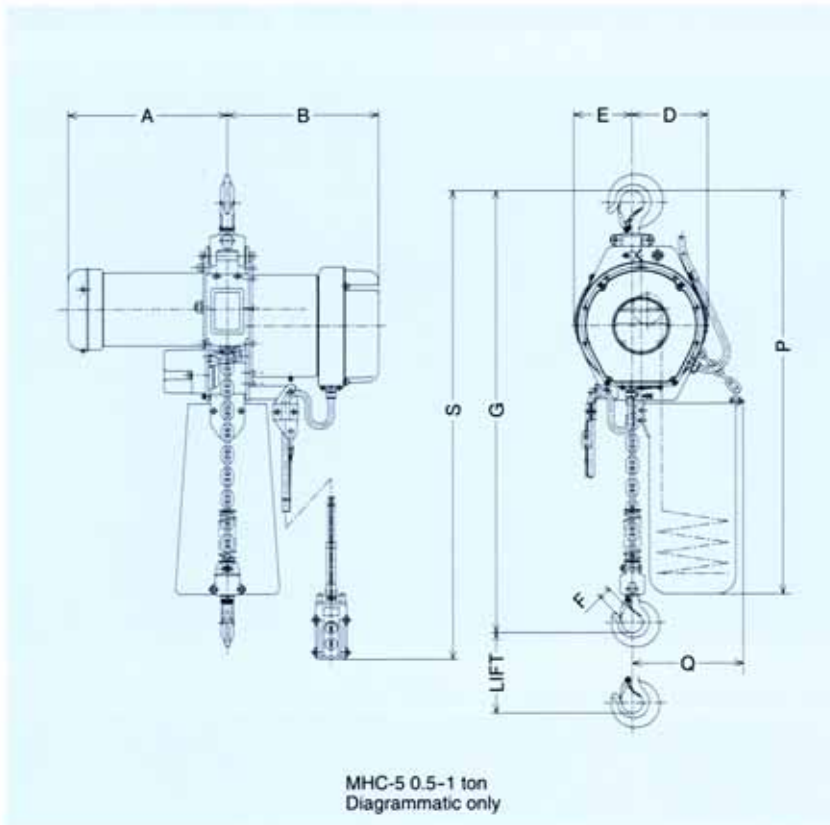

STANDARD SPECIFICATIONS : MHC-5 Electric Chain Hoist (Single-voltage)

Item No.	Rated load (ton)	Lift (m)	Hoisting Speed(m/min)		Hoist Motor 1-phase			Load Chain		Test Load (ton)	Minimum Headroom (Max.) G (mm)	Net Weight ⊗ (approx.) (≒kg)	Grade
			50Hz	60Hz	Output (kw)	Rating (min)	% ED	Dia (mm)	Nos.of falls				
MC5005	0.5	4.0	5.4	6.4	0.62	15	25	7.1	1	0.625	550	58	M5
MC5010	1		2.7	3.2					1	1.25	560	58	M5

Item No.	Rated load (ton)	Major Dimensions (approx.) (mm)							
		A	B	D	E	F	⊗P	⊗Q	S(m)
MC5005	0.5	305	285	152	106	20	690	220	3.6
MC5010	1	305	285	152	106	25		220	

N.B. The dimensions P and Q marked *above vary according to different lifts.

The design, materials and specifications are subject to change for improvements without notice.

NITCHI-MATIC ELECTRIC CHAIN HOISTS MODEL MH-5 (SLOW SPEED)

MODEL MH-5 SLOW SPEEDS

Single-fall slow speed versions of 0.5 ton through 2.0 ton Model MH-5 hoists are available for special load handling applications that require the slow and sure handling of loads.

Besides the slow speeds shown in the lower table, a range of other slow speeds are also available. Also slow speeds for 3.0 ton and larger capacities are available. Please consult your Nitchi dealer for further information on the available slow speeds.

STANDARD SPECIFICATIONS

Capacity (ton)	Lift (m)	Hoisting Speed(m/min)		Hoist Motor 3-Phase					Loab Chain		S(m)	Test Load (ton)	Drawn-up Dimension (Max.) G(mm)	Net Weight ※ (approx.) (kgf)	Grade
		50Hz	60Hz	Output(kw)		Ins. Class	Rating (min.)	% ED	Dia. (mm)	Nos. of falls					
				50Hz	60Hz										
0.5	4.0	4.3	5.1	0.83	1.0	B	30	40	7.1	1	3.6	0.625	530	53	V
1		3.3	3.9	0.83	1.0				7.1	1	3.6	1.25	550	55	V
2		3.0	3.5	2.5	3.0				11.2	1	3.8	2.5	725	100	V

S: Refer to the left-hand drawings.

The design, materials and specifications are subject to change for improvements without notice.

NITCHI-MATIC ELECTRIC CHAIN HOISTS MODEL MH-5 (LARGE CAPACITIES)

MODEL MH-5 LARGE CAPACITIES

The standard capacities of Model MH-5 range up to 50 ton. The large electric chain hoists are the result of Nitchi's highly advanced technology and long years of experience in manufacturing electric chain hoists.

The use of a single load chain fall 3 ton base electric chain hoists has made it possible for us to give the large capacity Model MH-5 faster hoisting speeds, smaller head-rooms and lighter weights without any loss of safety or durability.



STANDARD SPECIFICATIONS

Capacity (ton)	Lift (m)	Hoisting Speed (m/min)		Hoist Motor 3-Phase				Load Chain		S (m)	Test Load (ton)	Drawn-up Dimension (Max.) G (mm)	Net Weight ※ (approx.) (kgf)
		50Hz	60Hz	Output (kw)		Ins. Class	Rating (min.)	Dia. (mm)	Nos. of falls				
				50Hz	60Hz								
10	4.0	2.6	3.1	2.5×2	3.0×2	B	30	11.2	4	4.0	12.5	1,060	280
15		1.7	2.1	2.5×2	3.0×2			11.2	6	4.3	18.75	1,260	405
20		1.3	1.6	2.5×2	3.0×2			11.2	8	4.5	25	1,450	525
30		0.7	0.9	3.1×2	3.7×2			11.2	12	4.6	37.5	1,600	800
40		0.5	0.6	3.1×2	3.7×2			11.2	16	5.0	50	2,000	1,300
50		0.3	0.4	3.1×2	3.7×2			11.2	24	5.5	62.5	2,500	1,700

S: Refer to the left-hand drawings.

The design, materials and specifications are subject to change for improvements without notice.

SPECIAL VARIATIONS

The following are only a few of the special variations of MH-5 Series electric chain hoists that are available at moderate extra charges. Please contact your nearest NITCHI dealer or distributor without hesitation for further information on special variations:

MH-5 CE Version

The CE Version is a special variation made to suit the European market, which fulfills the requirements of the EN regulations. The CE Version has a friction type over load protection, an emergency stop control, and other modifications as standard equipment, which are in accordance with the EN regulations. The use of an extra powerful electro-magnetic brake makes it possible to remove the mechanical brake, and replace it with a friction type over load protection device. The trolleys for the CE Version are applicable to a wide variety of beam widths ranging up to extra wide, and are equipped with anti-drop plates.



Extra powerful electro-magnetic brake



Friction type over load protection

Dual-voltage MH-5

The power source voltage setting of a dual-voltage MH-5 electric chain hoist can be easily changed to low voltage (a voltage in the area of 200-volt) or to high voltage (a voltage in the area of 400-volt) by simply rearranging some of the wiring connections within the electric chain hoist. A 220/380-volt version and a 220/440-volt version are available. Please consult your nearest NITCHI dealer or distributor for information on other dual-voltages that are available.

High Lift Type MH-5

These are electric chain hoists with chain bucket assemblies for long lengths of load chain. The connecting methods of high lift type MH-5 electric chain hoists with trolleys are different from the standard connecting method used on non-long lift type MH-5 electric chain hoists with trolleys. Also, the chain bucket assemblies of hook suspended type long lift type MH-5 electric chain hoists require support chains to be connected to the structure supporting the electric chain hoists. The MH-5 electric chain hoists are classified to be "long lift type" electric chain hoists when the load-lifting heights of the right table are exceeded.

0.5 ton & 1 ton:	30.1 meters
2 ton:	20.1 meters
3 ton:	10.1 meters
5 & 7.5 ton:	10.1 meters
10 ton:	8.6 meters
15 ton & Larger:	Same for standard lifts and high lift type

MH-5 WITH LONG DUTY TIME RATING

MH-5 Electric chain hoists with long duty time ratings or MH-5 electric chain hoists for continuous operations are also available.

MOTORIZED TROLLEYS WITH SLOW TRAVERSING SPEED

The traversing speed of the motorized trolleys can be reduced to 1/2, 1/4 or 1/8 the standard traversing speed.

SPECIAL APPLICATIONS

A separate catalog for the following special applications is available on request:

1. Low head room electric chain hoist (0.5 ton to 5 ton)
2. 2-Point lifting electric chain hoist (0.5 ton to 3 ton)
3. Load rotator electric chain hoist (1 ton to 3 ton)
4. Diagonal pulling electric chain hoist (0.5 ton to 3 ton)
5. Load chain climbing electric chain hoist (1 ton and 2 ton)
6. Base mounted electric chain hoist (0.5 ton and 1 ton)

JAPANESE INDUSTRIAL STANDARD

Electric Chain Hoists

JIS B 8815- 1987

3.2 Grade

Chain hoists shall be graded as given in Table 2, with respect to mechanical parts such as gears and bearings, according to the load rate and running time.

Table 2. Grade

Load rate	Grade						
	Mean running time per day h	0.25 or under	Over 0.25 to 0.5 incl.	Over 0.5 to 1 incl.	Over 1 to 2 incl.	Over 2 to 4 incl.	Over 4 to 8 incl.
	Total running time h	400 or under	Over 400 to 800 incl.	Over 800 to 1600 incl.	Over 1600 to 3200 incl.	Over 3200 to 6400 incl.	Over 6400 to 12500 incl.
Light	Use at about 1/3 of rated load usually and at rated load rarely.	I	I	II	III	IV	V
Middle	Use at about 1/3 to 2/3 of rated load usually and at rated load at times.	I	II	III	IV	V	—
Heavy	Use at 2/3 of rated load or over usually and at rated load many times.	II	III	IV	V	—	—
Very heavy	Use at rated load or near load almost all the time.	III	IV	V	—	—	—

3.3 Classification of Motor Rating

Motor ratings shall be classified into short-time rating and intermittent periodic rating.

- (1) The short-time rating shall be as specified in Table 3.
- (2) The intermittent periodic rating shall be expressed as the load time rate (%ED) that is the rate of the load time to the sum of the load time and the rest time. The relationship between a load time rate and the maximum value of starting times in it shall be as given in Table 4.

Table 3. Short-Time Rating

Unit: min.

Type of Motor				
Motor for lifting		Motor for traversing		
7.5	10	15	20	30

Table 4. Intermittent Periodic Rating

Intermittent periodic rating	Type of Motor											
	Motor for lifting					Motor for traversing						
Load time rate %ED	15	20	25	30	40	50	10	15	20	25	30	40
Maximum starting times time/h	90	120	150	180	240	300	60	90	120	150	180	240

5.2 Load Chain

The load chain shall be surface hardened.

Note (7) The total depth of carburized case shall be measured in accordance with CD-H 0.3-T prescribed in JIS G 0557. In addition, the total depth of carburized case is equal to 2% or more of the wire diameter.

Table 8. Performance of Surface Hardened Load Chain

Wire dia. mm	Working load kN (kgf)	Proof load kN (kgf)	Breaking load kN (kgf)	Total ultimate elongation %	Surface hardness HV (0.3)	Total depth of carburized case (7) mm
7.1	12.5 { 1250 } max.	25 { 2500 }	63 { 6300 } min.	6 min.	600 min.	0.14 min.
11.2	31.5 { 3150 } max.	63 { 6300 }	160 { 16000 } min.	6 min.	600 min.	0.22 min.